

ROUNDTTEST RA-2200 SERIES

ROUNDNESS/CYLINDRICITY MEASURING SYSTEM
OFFERING HIGHEST PRECISION LEVEL IN ITS CLASS



ROUNDTEST RA-2200AS/DS/AH/DH

All models are equipped with a highly accurate turntable that enables simple and accurate centering and leveling of the workpiece, which account for the majority of the essential setup work for measuring roundness/cylindricity.

Wide variety of models available to suit any application

RA-2200AS/AH

The models are supplied as standard with an automatic centering and leveling turntable, freeing the operator from the centering and leveling task.

RA-2200DS/DH

The models are supplied as standard with a navigation function that quickly and simply guides the operator through the centering and leveling task, as though the task were being performed by an expert.

Both types have a column drive height of 300 mm (type S) or 500 mm (type H) for handling taller workpieces. All models can be combined with the basic, side-table system vibration-damping platform or the monitor-arm system vibrationdamping platform.



Space-saving design

Integrating the system vibration-damping platform (see figure page 6) has reduced the installation space by approximately 20-40% compared to Mitutoyo's earlier installation platforms. Additionally, a design with increased layout freedom greatly improves the measurement room utilization rate and measurement efficiency.

Sliding detector-unit holder provided as a standard feature

The detector-unit holder is equipped with a sliding mechanism, enabling one-touch measurement of a workpiece with a deep hole having a thick wall, which has been difficult with the conventional standard arm.

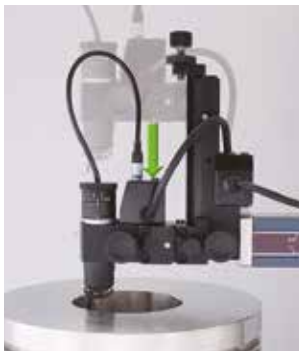

Sliding distance: 112 mm

The detector-unit holder can be stopped at a position sufficiently higher than the workpiece along the Z-axis, and then lowered and positioned to make measurements. Furthermore, internal/external diameters can be easily measured with the continuous internal/external diameter measurement function (for details see page 3).

Safety mechanism provided as a standard feature



A safety mechanism is incorporated into the detector unit area. A collision-sensing function has been added to the detector unit (when it is in the vertical orientation) to prevent collision in the Z-axis direction. Additionally, an accidental collision prevention function, which stops the system when the detector unit displacement exceeds its range, has been added. When an accidental touch is detected, the dedicated analysis software (ROUNDPAK) senses the error and automatically stops the system.

Equipped with a highly accurate turntable that enables simple and accurate centering and leveling of the workpiece

The table provides high rotational accuracy (radial $0.02+3.5H/10000 \mu\text{m}$; axial $0.02+3.5X/10000 \mu\text{m}$), enabling the system to measure flatness and other characteristics, in addition to roundness/cylindricity, at a level that suits any application.

For centering and leveling support, you can select either the A.A.T. (Automatic Adjustment Table) or D.A.T. (Digimatic Adjustment Table).

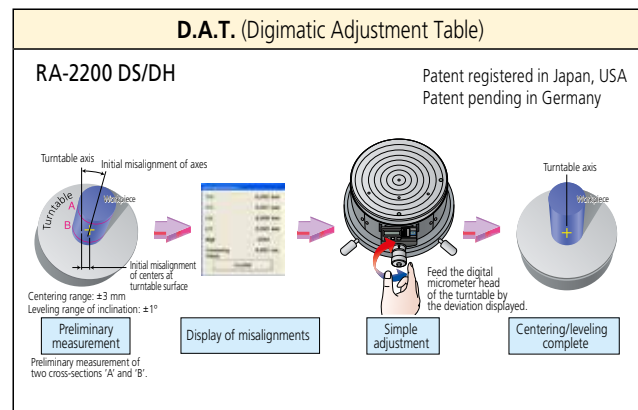
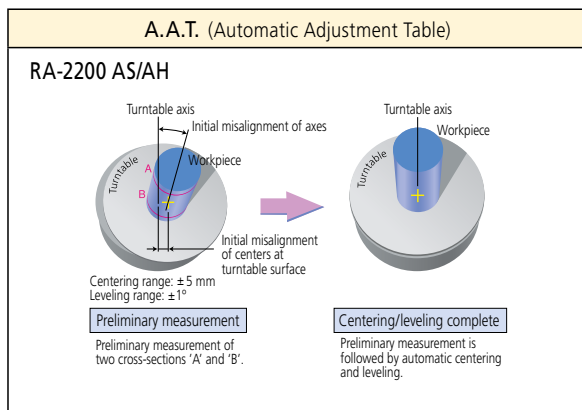

High accuracy even at high positioning speeds

Continual development has resulted in the highest drive speed within the class.

- Vertical direction (Z-axis column): Max. 50 mm/s
- Radial direction: Max. 30 mm/s

Continuous OD/ID measurement function

Patent registered in Japan, USA, Germany, UK, France

Continuous internal/external diameter measurement is possible without changing the detector position.



Highly accurate repeat measurements

Mitutoyo's linear scales are incorporated into the X-axis positioning sensor, directly sensing the displacement of the drive unit to achieve highly accurate positioning, which is essential for repeat measurements.

Partial circle measurement function

Even if a workpiece cannot be measured by physically rotating it by a full turn due to some obstruction (projection), segments of the circumference can be measured.

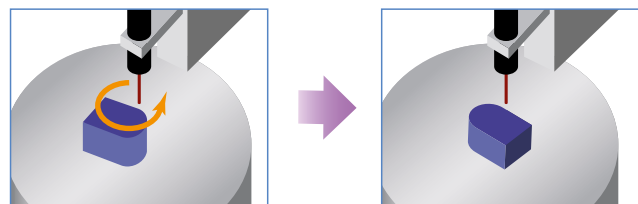

Spiral Measurement/Analysis

The spiral-mode measurement function combines table rotation and rectilinear action allowing cylindricity, coaxiality, and other data to be loaded as a continuous data set.



Measurement through X-axis tracking

Measurement while tracing is possible through a built-in linear scale in the X-axis. This type of measurement is useful when displacement due to form variation exceeds the measuring range of the sensor, and X-axis motion is necessary to maintain contact with the workpiece surface.



Specifications RA-2200 AS/DS/AH/DH

Model No.		RA-2200AS	RA-2200DS	RA-2200AH	RA-2200DH
Turntable unit	Rotational accuracy	(0.02+3.5H/10000) μm H: probing height (mm)			
		(0.02+3.5X/10000) μm X: distance from rotational center (mm)			
	Rotating speed	2, 4, 6, 10 rpm			
	Table effective diameter	ø 235 mm	ø 200 mm	ø 235 mm	ø 200 mm
	Centering/leveling adjustment	A.A.T	D.A.T	A.A.T	D.A.T
	Centering adjustment range	±3 mm	±5 mm	±3 mm	±5 mm
	Leveling adjustment range	±1°			
	Max. loading weight	30 kg			
	Max. probing diameter	ø 300 mm			
Max. loading diameter	ø 580 mm				
Vertical drive unit (Z-axis)	Straightness accuracy	0.10 μm/100 mm (λc 2.5) 0.15 μm/300 mm (λc 2.5)		0.10 μm/100 mm (λc 2.5) 0.25 μm/500 mm (λc 2.5)	
	Parallelism to rotation center	0.7 μm/300 mm (Referential generatrix line)		1.2 μm/500 mm (Referential generatrix line)	
	Traverse speed	Max. 50 mm/s (Measurement: 0.5/1.0/2.0/5.0 mm/s)			
	Max. probing height	300 mm		500 mm	
		300 mm		500 mm	
Radial drive unit (X-axis)	Straightness accuracy	0.7 μm/150 mm (λc 2.5)			
	Horizontal to rotation center	1.0 μm/150 mm (Referential generatrix line)			
	Travel amount	175 mm (from rotation center -25 mm~+150 mm)			
	Travel speed	Max. 30 mm/s (Measurement: 0.5/1.0/2.0/5.0 mm/s)			
Detector	Measuring force	10 ~ 50 mN (switching 5 levels) (ID/OD measurement style with standard stylus)			
	Stylus design, material	ø 1.6 mm tungsten carbide ball			
	Measuring range	±400 μm/±4 μm/±4 μm			
		±5 mm			
Other	Power supply	100V ~ 240V			
	Air pressure	0.39 MPa			
	Air consumption	30 L/min (standard state)			
	Weight (measurement main unit)	180 kg		200 kg	

Dimensions

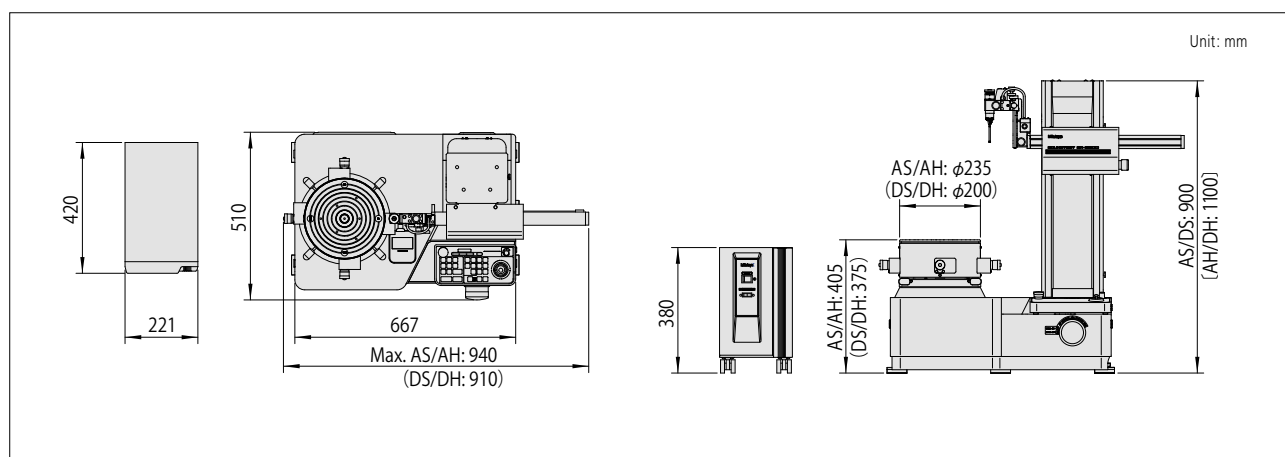

Optional Accessories

Styli for RA-2200 (Option)

Type	Standard (Standard accessory)	Notch *2	Deep groove *2	Corner	Cutter mark
Order No.	12AAL021	12AAL022	12AAL023	12AAL024	12AAL025
Stylus tip	ø1.6 mm tungsten carbide	ø3 mm tungsten carbide	SR0.25 mm sapphire	SR0.25 mm sapphire	tungsten carbide
Dimensions (mm)					
Type	Small hole (ø0.8)	Small hole (ø1.0) *2	Small hole (ø1.6)	Extra small hole (Depth 3 mm)	ø1.6 mm ball *2
Order No.	12AAL026	12AAL027	12AAL028	12AAL029	12AAL030
Stylus tip	ø0.8 mm tungsten carbide	ø1 mm tungsten carbide	ø1.6 mm tungsten carbide	ø0.5 mm tungsten carbide	ø1.6 mm tungsten carbide
Dimensions (mm)					
Type	Disk	Crank (ø0.5)	Crank (ø1.0)	Flat surface	2X-long type *1 *2
Order No.	12AAL031	12AAL032	12AAL033	12AAL034	12AAL035
Stylus tip	ø12 mm tungsten carbide	ø0.5 mm tungsten carbide (Depth 2.5 mm)	ø1 mm tungsten carbide (Depth 5.5 mm)	tungsten carbide	ø1.6 mm tungsten carbide
Dimensions (mm)					
Type	2X-long type notch *1	2X-long type deep groove *1	2X-long type corner *1	2X-long type cutter mark *1	2X-long type Small hole *1
Order No.	12AAL036	12AAL037	12AAL038	12AAL039	12AAL040
Stylus tip	ø3 mm tungsten carbide	SR0.25 mm sapphire	SR0.25 mm sapphire	tungsten carbide	ø1 mm tungsten carbide
Dimensions (mm)					
Type	3X-long type *3	3X-long type deep groove *3	Stylus shank	Stylus shank(standard groove)	Stylus shank(2X-long groove)*1
Order No.	12AAL041	12AAL042	12AAL043	12AAL044	12AAL045
Stylus tip	ø1.6 mm tungsten carbide	SR0.25 mm sapphire	For mounting CMM stylus (mounting thread M2)	For mounting CMM stylus (mounting thread M2)	For mounting CMM stylus (mounting thread M2)
Dimensions (mm)					

*1: Measuring in the horizontal direction with detector 12AAF203.

*2: Part of the 5-piece styli set 12AAL020.

*3: Measuring is only possible in the vertical direction.

ROUNDTTEST EXTREME RA-2200CNC



RA-2200CNC+vibration isolator with side table

Highly accurate turntable

The table provides high rotational accuracy (radial $0.02+3.5H/10000 \mu\text{m}$; axial $0.02+3.5X/10000 \mu\text{m}$), enabling the system to measure flatness and other characteristics, in addition to roundness/cylindricity, at a level that suits any application.

Space-saving design

Integrating the system vibration-damping platform has significantly reduced the installation space requirements. Additionally, any layout can be achieved by combining the system with a PC table.

Highly accurate positioning sensor

A Mitutoyo linear scale is incorporated into the X-axis positioning sensor, directly sensing the displacement of the drive unit to achieve highly accurate positioning, which is essential for repeat measurements. Furthermore, continual development has resulted in the highest drive speed within the class while achieving high accuracy even at high positioning speeds.

Detector unit orientation programmable for CNC measurement

This function controls the orientation of the arm holding the detector unit (between vertical and horizontal) and the detector unit rotation mechanism (between 0 and 270 degrees in 1-degree increments), making it possible to continuously and automatically measure internal/external diameters as well as top/bottom surfaces. Additionally, a full-featured offline teaching function simplifies the creation of part programs.



Simple and accurate centering and leveling of the workpiece

The system comes standard with the A.A.T. (Automatic Adjustment Table) positioning and leveling function, freeing the operator from the task of centering and leveling the workpiece.

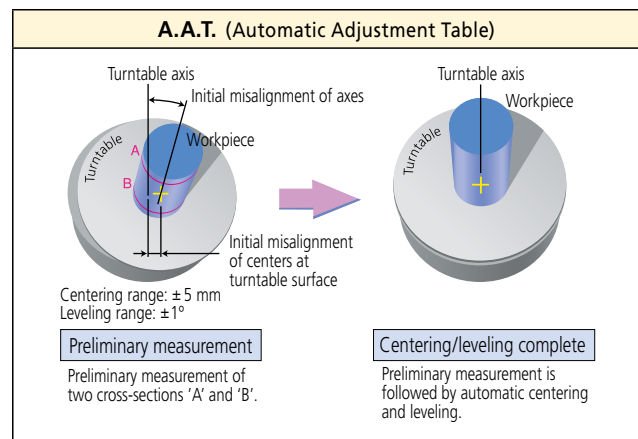

Roughness detector unit support

When an optional roughness detector unit is incorporated into the system it can measure workpiece surface roughness in the circumferential direction around the axis of rotation, as well as roughness in the direct-drive directions along the X- and Z-axes with the table stopped.



Specifications RA-2200CNC

Model No.		RA-2200 CNC		
Z-axis		Standard column	High column	
Turntable unit	Rotational accuracy	(0.02+3.5H/10000) μm H: probing height (mm)		
	Radial direction	(0.02+3.5X/10000) μm X: distance from rotational center (mm)		
	Axial direction			
	Rotating speed	2, 4, 6, 10 rpm		
	Table effective diameter	ø 235 mm		
	Centering/leveling adjustment	A.A.T		
	Centering adjustment range	±3 mm		
	Leveling adjustment range	±1°		
	Max. loading weight	30 kg		
Max. probing diameter	ø 256 mm			
Max. loading diameter	ø 580 mm			
Vertical drive unit (Z-axis)	Straightness accuracy	0.10 μm/100 mm (λc2.5) 0.15 μm/300 mm (λc2.5)	0.10 μm/100 mm (λc2.5) 0.25 μm/500 mm (λc2.5)	
	Parallelism to rotation center	0.7 μm/300 mm (Referential generatrix line) 1.2 μm/500 mm (Referential generatrix line)		
	Traverse speed	Max. 50 mm/s (Measurement: 0.5/1.0/2.0/5.0 mm/s)		
	Max. probing height	300 mm	500 mm	
	ID	300 mm	500 mm	
Max. probing depth	26 mm for ø12.7 mm or more, 104 mm for ø32 mm or more (with standard stylus)			
Radial drive unit (X-axis)	Straightness accuracy	0.7 μm/150 mm (λc2.5)		
	Horizontal to rotation center	1.0 μm/150 mm (Referential generatrix line)		
	Travel amount	175 mm (from rotation center -25 mm~+150 mm)		
	Travel speed	Max. 30 mm/s (Measurement: 0.5/1.0/2.0/5.0 mm/s)		
Detector	Measuring force	40 mN		
	Stylus design, material	ø 1.6 mm tungsten carbide		
	Measuring range	Standard	±400 μm / ± 40 μm / ± 4 μm	
		Follow	±5 mm	
Other	Rotating mechanism (within the range 0° to 270°, in increments of 1°)			
Other	Power supply	100 V ~ 240 V		
	Air pressure	0.39 MPa		
	Air consumption	30 L/min (standard state)		
	Weight (measurement main unit)	180 kg	200 kg	

Dimensions

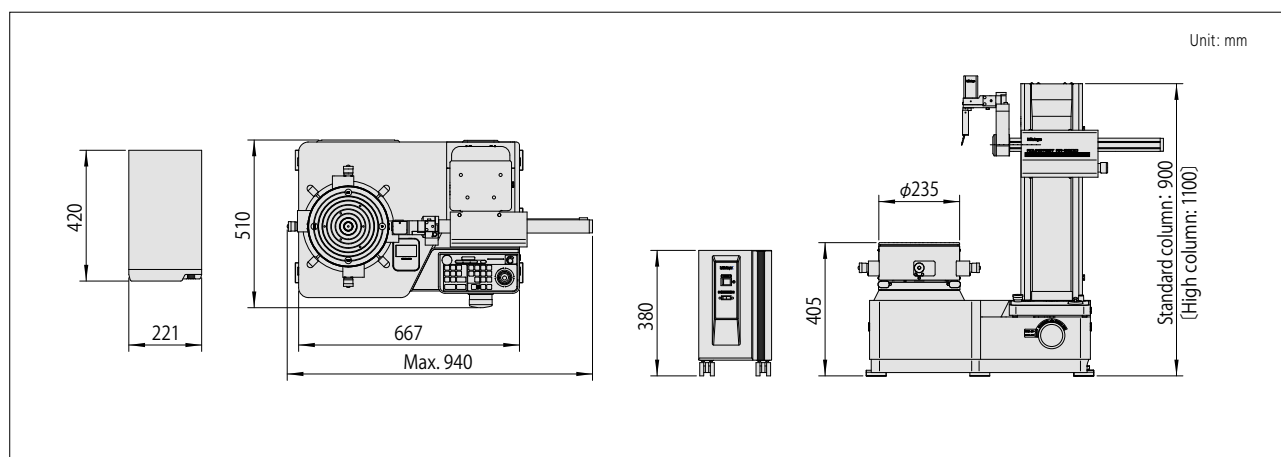

Styli for RA-2200CNC (Option)

Type	Deep groove	Flat surface	Standard	Notch	Deep hole A
Order No.	12AAE310	12AAE302	12AAE301	12AAE309	12AAE306
Stylus tip	ø 1.6mm tungsten carbide	ø 1.6mm tungsten carbide	ø 1.6mm tungsten carbide	ø 3mm tungsten carbide	ø 1.6mm tungsten carbide
Dimensions (mm)					
Type	ø 1.6 mm ball	ø 0.8 mm ball	ø 0.5 mm ball	Deep groove	Deep hole B
Order No.	12AAE303	12AAE304	12AAE305	12AAE308	12AAE307
Stylus tip	ø 1.6mm tungsten carbide	ø 0.8mm tungsten carbide	ø 0.5mm tungsten carbide	ø 1.6mm tungsten carbide	ø 1.6mm tungsten carbide
Dimensions (mm)					

Options common to the RA-2200AS/DS/AH/DH, RA-2200CNC



Centering chuck (key operated)

211-014

Suitable for holding longer parts and those requiring a relatively powerful clamp.

- Holding capacity:
Internal jaws: OD = ø2 - ø35 mm,
ID = ø25 - ø68 mm
External jaws: OD = ø35 - ø78 mm
- External dimensions: ø157 x 70.6 mm
- Mass: 3.8 kg



Centering chuck (ring operated)

211-032

Suitable for holding small parts with easy-to-operate knurled-ring clamping.

- Holding capacity:
Internal jaws: OD = ø1 - ø36 mm,
ID = ø16 - ø69 mm
External jaws: OD = ø25 - ø79 mm
- External dimensions: ø118 x 41 mm
- Mass: 1.2 kg



Micro-chuck

211-031

Used for clamping a workpiece (less than ø1 mm dia.) that the centering chuck cannot handle.

- Holding capacity: ø 0.1-ø1.5 mm
- External dimensions: ø 107 x 48.5 mm
- Mass: 0.6 kg



Magnification calibration gage

211-045

Used for normalizing detector magnification by calibrating detector travel against displacement of a micrometer spindle.

- Maximum calibration range: 400µm
- Graduation: 0.2µm
- External dimensions: 235 (max) x 185 x 70mm
- Mass: 4 kg

Cylindrical square

350850

- Straightness: 0.5 µm
- Cylindricity: 2 µm
- External dimensions: ø70 x 250 mm
- Mass: 7.5 kg

Monitor arm



ROUNDPAK

Analysis software provides user-friendly operations.

Simple operations even with a full set of parameters and analysis functions

A wide variety of parameters including those for roundness/cylindricity, as well as flatness and parallelism, are provided as standard features. You can visually select these parameters using icons.

ROUNDPAK also comes with specialized functions, such as the design value best-fit analysis function, the harmonic analysis function, and a function for recording the peak or trough points on a circumference. Data that has already been collected can be easily used for re-calculation, or deleted.

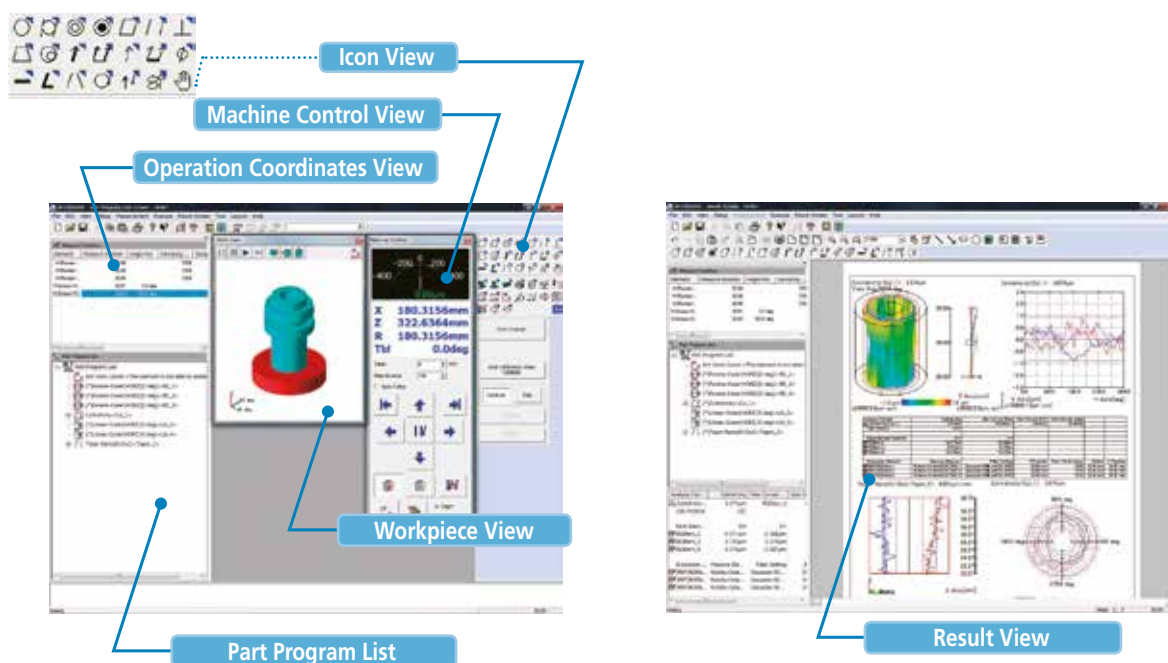

Recalculation

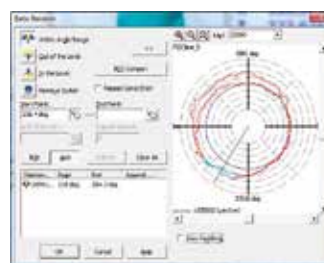

Data deletion

Freedom in laying out the graphics and data obtained from measurements

The customer can create reports in custom formats by specifying how the analysis results will be displayed, as well as the sizes and positions of graphics. The analysis result window can be directly utilized as a layout window. Since the measurement procedure, including the layout information, is saved, the entire process, from measurement start, calculation, result saving, and finally to printing, can be automatically executed.

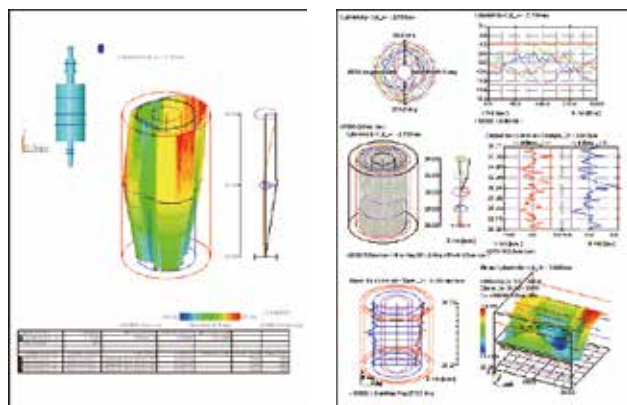

A wide variety of graphics functions

Analysis results such as cylindricity and coaxiality can be visually expressed in 3D graphics.

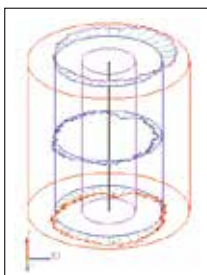

Normal display

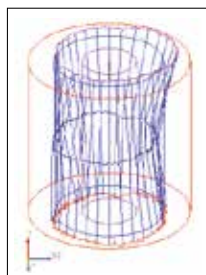

Wire-frame display

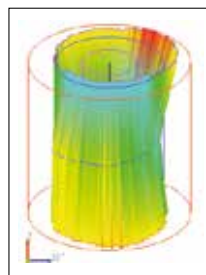

Surface-map display



Shading display

Off-line measurement procedure programming function

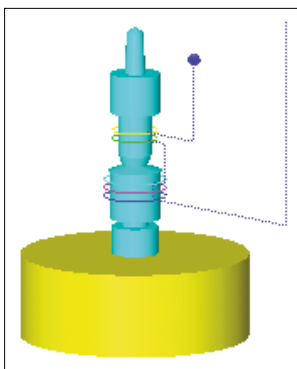

Patent registered in Japan, USA
Patent pending in Europe

An offline teaching function is provided to create a part program (measurement procedure) without an actual measurement target, enabling the user to virtually execute the measurement operation in a 3D simulation window.



**Whatever your challenges are,
Mitutoyo supports you from start to finish.**

Mitutoyo is not only a manufacturer of top quality measuring products but one that also offers qualified support for the lifetime of the equipment, backed up by comprehensive services that ensure your staff can make the very best use of the investment.

Apart from the basics of calibration and repair, Mitutoyo offers product and metrology training, as well as IT support for the sophisticated software used in modern measuring technology. We can also design, build, test and deliver bespoke measuring solutions and even, if deemed cost-effective, take your critical measurement challenges in-house on a sub-contract basis.

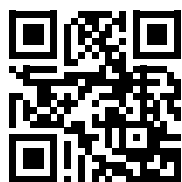

**Find additional product literature
and our product catalogue**

www.mitutoyo.eu

Note: All our product details, in particular the illustrations, drawings, dimensional and performance details and other technical specifications contained in this publication are to be considered to be approximate average values. To this extent, we reserve the right to make changes in design, technical data, dimensions and weight. Our specified standards, similar technical rules and technical specifications, descriptions and illustrations of the products are correct at the time of printing. The current version of our general terms and conditions also apply. Only offers which we have submitted can be considered to be definitive.

Mitutoyo

Mitutoyo Europe GmbH

Borsigstraße 8-10
41469 Neuss

Tel. +49 (0) 2137-102-0
Fax +49 (0) 2137-102-351

info@mitutoyo.eu
www.mitutoyo.eu